

Drop-In
Drop-in refrigerated well, static with fan
(2 GN container capacity) and A
overshelf

ITEM # _____

MODEL # _____

NAME # _____

SIS # _____

AIA # _____

341174 (D11C20)

 Drop-in Refrigerated Well,
 static with fan (2 GN
 container capacity) with one
 A type overshelf and LED
 light

Short Form Specification

Item No. _____

Hydrocarbon refrigerant gas R290 for the lowest environmental impact (GWP=3) - CFC and HCFC free. Designed to serve the food in gastrorm containers. Well in 304 AISI stainless steel with rounded corners to facilitate cleaning operations. The well is also equipped with a drain hole. Automatic defrosting guarantees evaporators clearance and efficient well cooling. High-density expanded polyurethane foam with cyclopentane guarantees excellent well insulation to reduce energy dispersion. A constant flow of cold air circulating through the containers guarantees the correct food temperatures. Temperature uniformity and fast cool down times are guaranteed thanks to powerful radial booster fans. Cylindrical stainless steel air diffusors provides a constant air circulation. 84% faster cool down time (than static refrigerated well) reduces energy consumption by allowing the operator to switch the machines on only when needed. The bottom is equipped with copper tubes to ensure proper cooling, with this system the air touches the cold surface and gets cooled. Then cooled air is being distributed with radial booster fans. Stylish A type overshelf designed for extra increased visibility on the surface for charming food display. Overshelf equipped with LED lights.

Main Features

- Suitable for GN 1/1 containers with a maximum height of 150 mm.
- CB and CE certified by a third party notified body.
- Designed to serve the food in gastrorm containers.
- Precise temperature control and setting at 0,1°C .
- As standard the product comes with digitally controlled thermostat which is in line of HACCP norms and provides visual alarm as a warning of the increasing or decreasing temperatures.
- Food introduced at the correct temperature maintains its core temperature according to Afnor Standards.
- Automatic defrosting guarantees evaporators clearance and efficient well cooling.
- A constant flow of cold air circulating through the containers guarantees the correct food temperatures. Temperature uniformity and fast cool down times are guaranteed thanks to powerful radial booster fans. Cylindrical stainless steel air diffusors provides a constant air circulation.
- Stylish A type overshelf designed for extra increased visibility on the surface for charming food display.
- Overshelf equipped with LED lights.
- Designed to be positioned in flush installation providing improved cleanability and suitable for modern design installations.

Construction

- Well bottom is inclined to facilitate water drainage.
- Well in 304 AISI stainless steel with rounded corners to facilitate cleaning operations. The well is also equipped with a drain hole.
- Electronic control with temperature display.
- IPx2 water protection.
- The bottom is equipped with copper tubes to ensure proper cooling, with this system the air touches the cold surface and gets cooled. Then cooled air is being distributed with radial booster fans.

APPROVAL: _____

- Overshelf in complete AISI 304.

Sustainability



- Hydrocarbon refrigerant gas R290 for the lowest environmental impact (GWP=3) - CFC and HCFC free.
- High-density expanded polyurethane foam with cyclopentane guarantees excellent well insulation to reduce energy dispersion.
- 84% faster cool down time (than static refrigerated well) reduces energy consumption by allowing the operator to switch the machines on only when needed.

Front

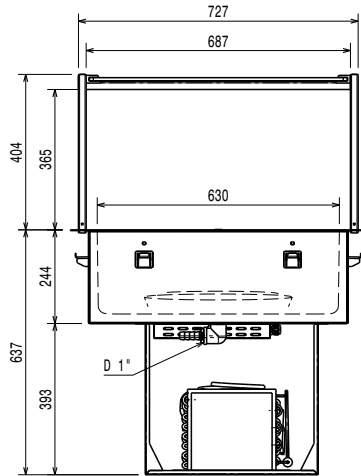

Side

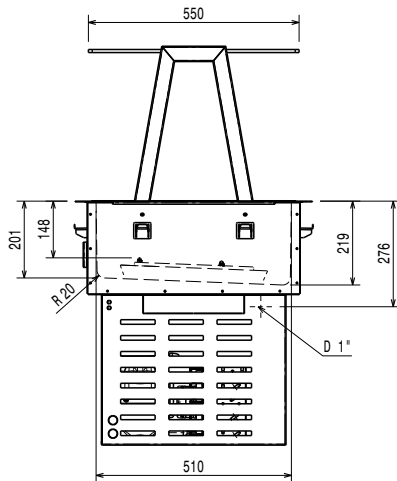

EI = Electrical inlet (power)

Top

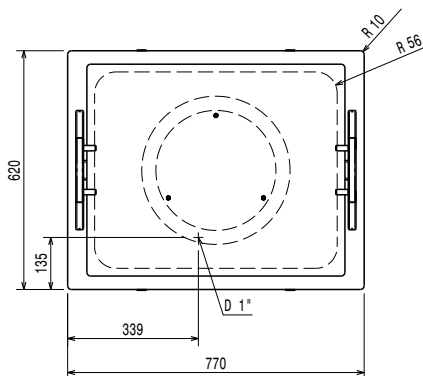

Electric

Supply voltage:

341174 (D11C20)

220-240 V/1N ph/50 Hz

Electrical power max.:

0.47 kW

Water:

Water drain outlet size:

Key Information:

External dimensions, Width: 770 mm

External dimensions, Depth: 620 mm

External dimensions, Height: 999 mm

Net weight: 59.46 kg

Shipping weight: 78 kg

Shipping height: 1320 mm

Shipping width: 670 mm

Shipping depth: 810 mm

Shipping volume: 0.72 m³
Set temperature: -10 / 0 °C

Refrigeration Data

Refrigerant type: R290

Sustainability

Noise level: 62 dBA

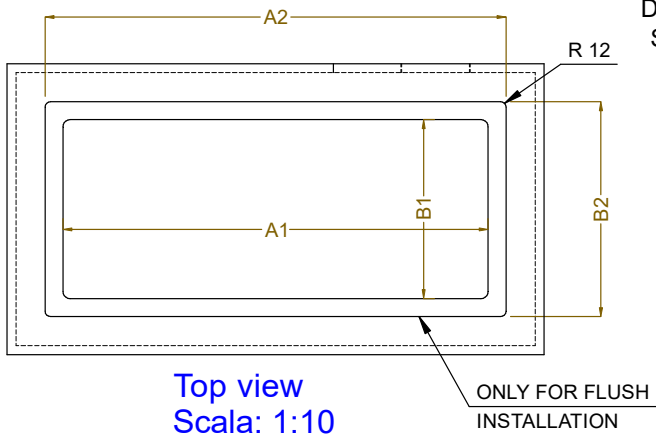
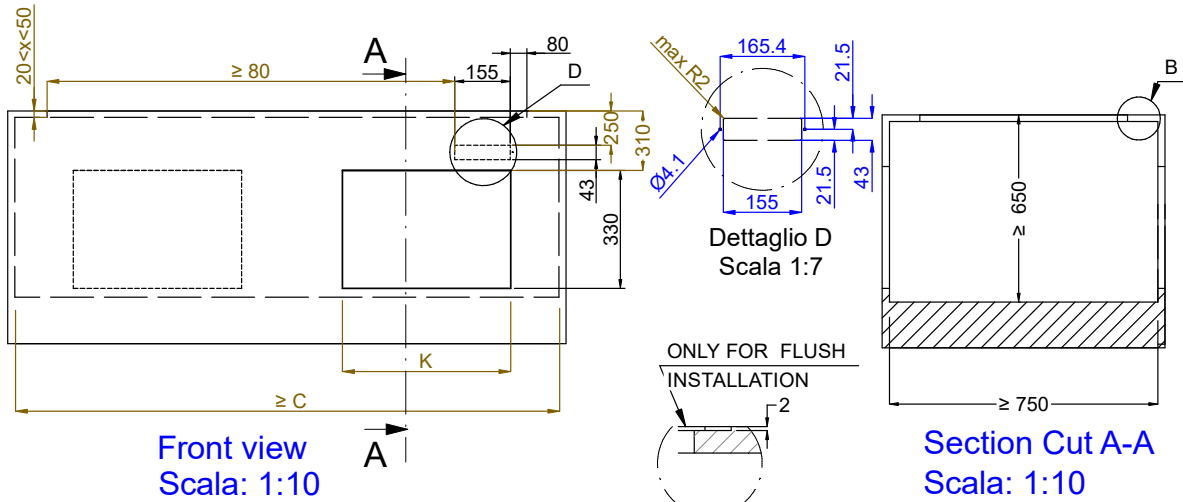

| CAPACITY | CUTOUT | | LOWERING FOR FLUSH INSTALLATION | | C | K |
|----------|--------|-----|---------------------------------|-----|------|-----|
| | A1 | B1 | A2 | B2 | | |
| 2GN | 740 | | 774 | | 880 | |
| 3GN | 1070 | 580 | 1104 | 624 | 1200 | 470 |
| 4GN | 1390 | | 1424 | | 1530 | |

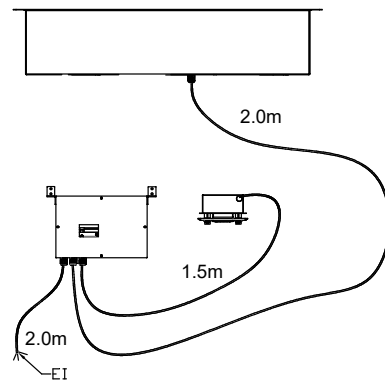
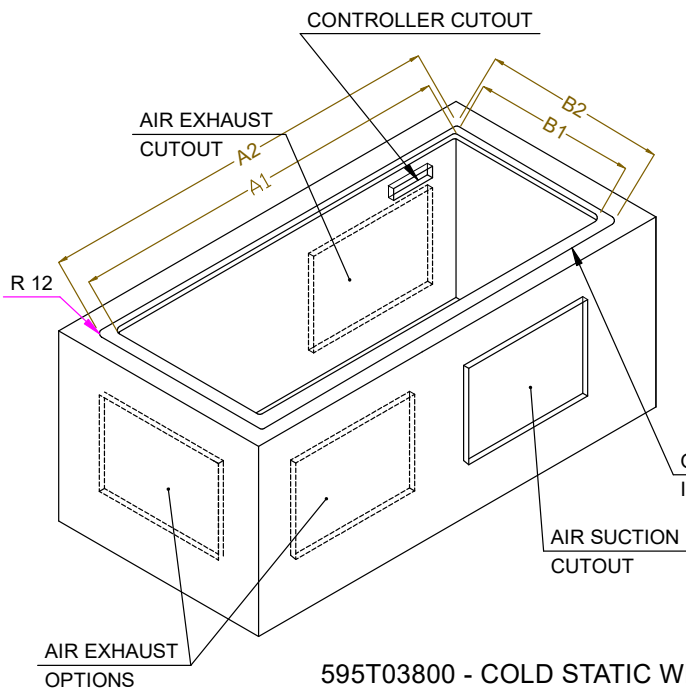

595T03800 - COLD STATIC WELL WITH FAN OVERSH. ON THE FRAME